

The MAC 500 series is designed to interface with the Ford/Chrysler standard base. This series is available in the following configurations:

- single or double solenoid
- 2 or 3 position
- single or dual pressure
- with or without indicator lights
- various electrical connections and manual operations

Valves and bases must be ordered separately. These may be assembled prior to shipping by adding the suffix -9 after the valve code.

EXAMPLE: MAC 500A-V1B1-PM-111DA-9
MAC 500A-B21A-9

SPECIAL APPLICATION INSTRUCTIONS

The 'A' cylinder port is normally open. On a spring return valve, the spring is the 'A' operator, the solenoid the 'B' operator. Energizing the 'B' operator pressurizes the 'B' port; energizing the 'A' operator pressurizes the 'A' port.

EXTERNAL PILOT APPLICATIONS

An external pilot supply is only required when the main valve pressure is less than 25 psi on single solenoid or 3 position valves and less than 10 psi on double solenoid 2 position valves. Pipe the external pilot supply to the External Pilot Port supplied in the valve base or manifold.

VACUUM APPLICATIONS

(2-Pos. Valves Only) - Use an External Pilot model as described above and also connect the vacuum source to the Exhaust Port and leave the Inlet Port open to atmosphere. The Inlet port may be connected to a pressure source to provide a selector application (vacuum/pressure).

SELECTOR APPLICATIONS

Use an External Pilot Model as described above if both pressures are below the minimum, otherwise use an Internal Pilot Model and connect the higher pressure to the Inlet Port and the lower to Port EA or EB depending on which cylinder port is to be active.

FORD

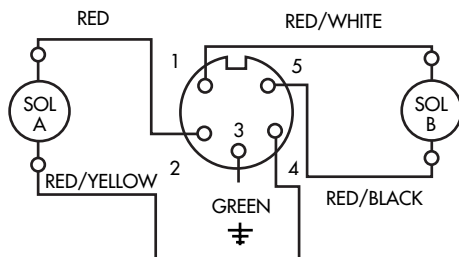

CHRYSLER

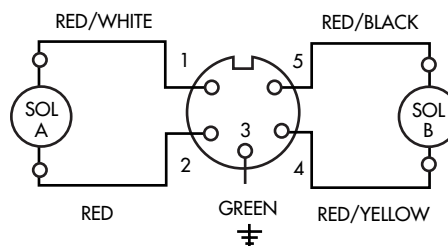

4 PIN CONNECTOR : SINGLE

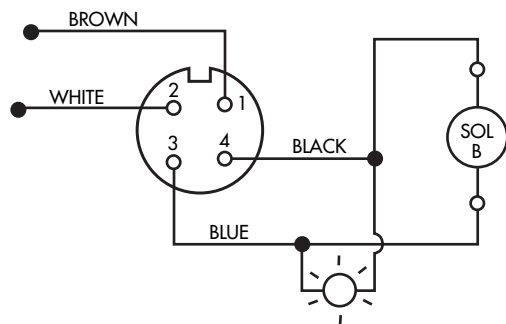

4 PIN CONNECTOR : DOUBLE

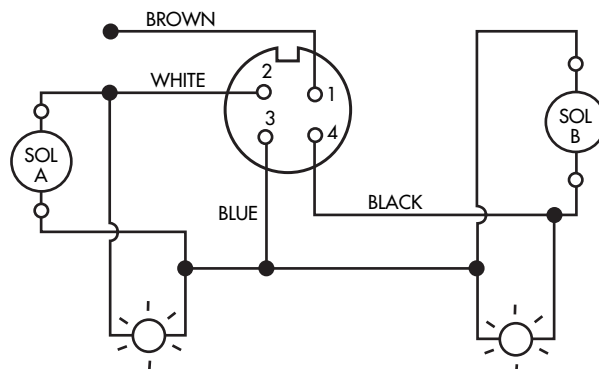

Function	Port size	Flow [Max]	Individual mounting	Series
5/2 - 5/3	1" - 1 1/4"	11.2 C_v	valve only	

OPERATIONAL BENEFITS





1. Balanced spool, immune to variations of pressure.
2. Short stroke with high flow.
3. High shifting forces.
4. Checked accumulator guarantees maximum pilot pressure
5. Powerful return force thanks to the combination of mechanical and air springs.
6. Bonded spool with minimum friction, shifting in a glass-like finished bore.
7. Wiping effect eliminates sticking.
8. Pilot valve with balanced poppet, high flow, short and consistent response times.



35
100
200
55
56
57
58
59

HOW TO ORDER

SINGLE PRESSURE VALVES (WITH LIGHTS)

Electrical connector	Pilot air	5/2 Single operator	5/2 Double operator	5/3 Closed center	5/3 Open center
					
5 PIN (Ford wired)	Internal	MAC500A-V1A2-PM- XXY -DA	MAC500A-V2A2-PM- XXY -DA	MAC500A-V5A2-PM- XXY -DA	MAC500A-V6A2-PM- XXY -DA
	External	MAC500A-V1A4-PM- XXY -DA	MAC500A-V2A4-PM- XXY -DA	MAC500A-V5A4-PM- XXY -DA	MAC500A-V6A4-PM- XXY -DA
5 PIN (Chrysler wired)	Internal	MAC500A-V1B2-PM- XXY -DA	MAC500A-V2B2-PM- XXY -DA	MAC500A-V5B2-PM- XXY -DA	MAC500A-V6B2-PM- XXY -DA
	External	MAC500A-V1B4-PM- XXY -DA	MAC500A-V2B4-PM- XXY -DA	MAC500A-V5B4-PM- XXY -DA	MAC500A-V6B4-PM- XXY -DA
4 PIN	Internal	MAC500A-V1G2-PM- XXY -DA	MAC500A-V2G2-PM- XXY -DA	MAC500A-V5G2-PM- XXY -DA	MAC500A-V6G2-PM- XXY -DA
MICRO	External	MAC500A-V1G4-PM- XXY -DA	MAC500A-V2G4-PM- XXY -DA	MAC500A-V5G4-PM- XXY -DA	MAC500A-V6G4-PM- XXY -DA
3 PIN (Ford wired)	Internal	MAC500A-V1E2-PM- XXY -DA	MAC500A-V2E2-PM- XXY -DA	MAC500A-V5E2-PM- XXY -DA	MAC500A-V6E2-PM- XXY -DA
	External	MAC500A-V1E4-PM- XXY -DA	MAC500A-V2E4-PM- XXY -DA	MAC500A-V5E4-PM- XXY -DA	MAC500A-V6E4-PM- XXY -DA
5 PIN MICRO (Chrysler wired)	Internal	MAC500A-V1F2-PM- XXY -DA	MAC500A-V2F2-PM- XXY -DA	MAC500A-V5F2-PM- XXY -DA	MAC500A-V6F2-PM- XXY -DA
	External	MAC500A-V1F4-PM- XXY -DA	MAC500A-V2F4-PM- XXY -DA	MAC500A-V5F4-PM- XXY -DA	MAC500A-V6F4-PM- XXY -DA

45
700
900
82

DUAL PRESSURE VALVES (WITH LIGHTS)

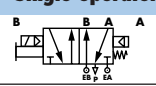
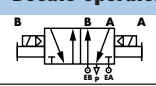
Electrical connector	Pilot air	5/2 Single operator	5/2 Double operator
			
5 PIN (Ford wired)	External	MAC500A-V3A4-PM- XXY -DA	MAC500A-V4A4-PM- XXY -DA
5 PIN (Chrysler wired)	External	MAC500A-V3B4-PM- XXY -DA	MAC500A-V4B4-PM- XXY -DA
4 PIN MICRO	External	MAC500A-V3G4-PM- XXY -DA	MAC500A-V4G4-PM- XXY -DA
3 PIN (Ford wired)	External	MAC500A-V3E4-PM- XXY -DA	MAC500A-V4E4-PM- XXY -DA
5 PIN MICRO (Chrysler wired)	External	MAC500A-V3F4-PM- XXY -DA	MAC500A-V4F4-PM- XXY -DA

6300
6500
6600
1300
800

SOLENOID OPERATOR ➤

XX Y DA*

XX Voltage	Y Manual operator
11 120/60, 110/50	1 Non-locking
12 240/60, 220/50	2 Locking
22 24/60, 24/50	
59 24 VDC (2.5 W)	
87 24 VDC (17.1 W)	
61 24 VDC (8.5 W)	

ISO 1
ISO 2
ISO 3
MAC 125A
MAC 250A
MAC 500A

* Other options available, see page 357.

Note : Valves are supplied without base. For base code see page 291.

TECHNICAL DATA

Fluid :	Compressed air, vacuum, inert gases	
Pressure range :	Internal pilot : single operator and 3 positions : 25-150 PSI	double operator : 10-150 PSI
	External pilot : vacuum to 150 PSI	
Pilot pressure :	Single operator and 3 positions : 25-150 PSI Double operator : 10-150 PSI	
Lubrication :	Not required, if used select a medium aniline point lubricant (between 180°F to 210°F)	
Filtration :	40 µ	
Temperature range :	0°F to 120°F (-18°C to 50°C)	
Flow (at 6 bar, ΔP=1bar) :	1" : (11.0 C _v), 1 1/4" : (11.2 C _v)	
Coil :	Epoxy encapsulated - class A wires - Continuous duty	
Voltage range :	-15% to +10% of nominal voltage	
Protection :	Consult factory	
Power :	- Inrush : 14.8 VA Holding : 10.9 VA = 1 to 17.1 W	

Spare parts :

- Solenoid operator (power ≥ 4 W) : D1-XXAA, cover mounting screws 35206 and seal 16234.
- Pilot valve : PME-XXYZZ, including seal 16337. • Pressure seal between valve and base : 16535
- Mounting screw valve to base (x3) : 32434.

DIMENSIONS

Dimensions shown are metric (mm)

