



Comprehensive Range of Approvals:

US Approvals				
Hazardous Location per NEC 500	Type of Protection	Class	Division	Group
	Explosionproof	1	1	A, B, C, D
	Dust-Ignitionproof	2	1	E, F, G
Hazardous Location per NEC 505, 506	Type of Protection	Zone	Group	
	AEx db IIC T4 Gb	1	IIC	
	AEx tb IIIC T135CDb	21	IIIC	
Enclosure Type	NEMA 4/IP66			

Canada Approvals				
Hazardous Location per CEC Sec 18 & Annex J	Type of Protection	Class	Division	Group
	Explosionproof	1	1	B, C, D
	Dust-Ignitionproof	2	1	E, F, G
Hazardous Location per NEC 505, 506	Type of Protection	Zone	Group	ELP
	Ex db IIC T4 Gb	1	IIC	Gb
	Ex tb IIIC T135 CDb	21	IIIC	Db
Enclosure Type	NEMA 4/IP66			

ATEX Certification	
Gas/Vapour	 II 2 G Ex db IIC T4 Gb
Dust	 II 2 D Ex tb IIIC T135C Db

IECEx Certification	
Gas/Vapour	Ex db IIC T4 Gb
Dust	Ex tb IIIC T135C Db

Please note, that valves must be wired in compliance with applicable electrical codes.

How to Order Valves with Hazardous Location D-Pilot

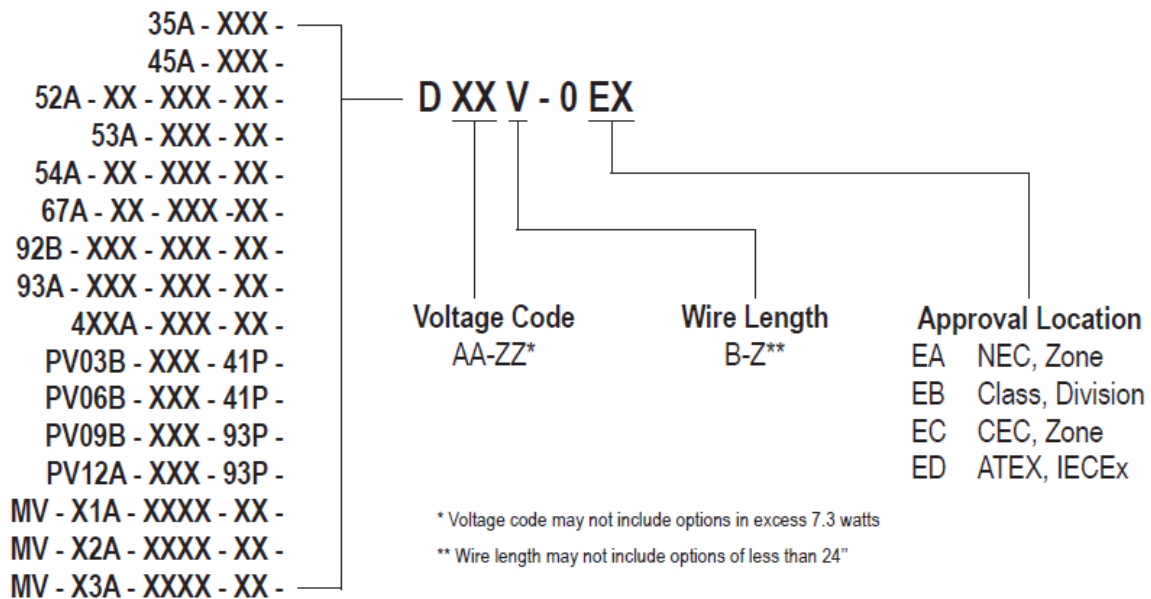

The list above represents current compatibilities with the Hazardous Locations approved D-coil. Additional series could be modified to accept a hazardous location pilot if necessary.

ISO 1 Requires additional Modification. Consult Factory.

MODS

The Hazardous Locations D-Coil is compatible with many existing modifications; however, all requests for Modifications will be subject to review by Product Development.

Optional Kits and Spacers

The size of the Hazardous Location electrical enclosure will for some Series necessitate the use of pilot spacers. While these spacers will be included as part of the build when ordering complete valves, they will need to be ordered separately for your own conversions. Please see drawings with annotations on subsequent pages.

- 89186 – Optional 35 Series spacer block
- N-45047 - Optional 45 Series spacer kit
- N-04015 – Optional 400 Series Namur spacer kit
- N-D0001* – Pilot Spacer kit

* Req'd for 53, 54, 92 and 93 Series. Also req'd for 52, 400 except manifold body.

35A-AAA-DXXB-0EX shown with optional spacer

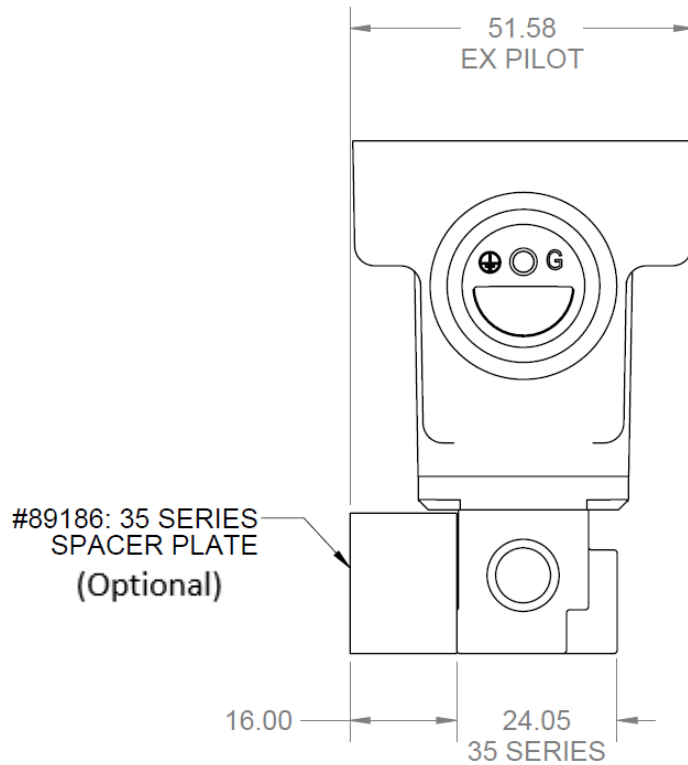
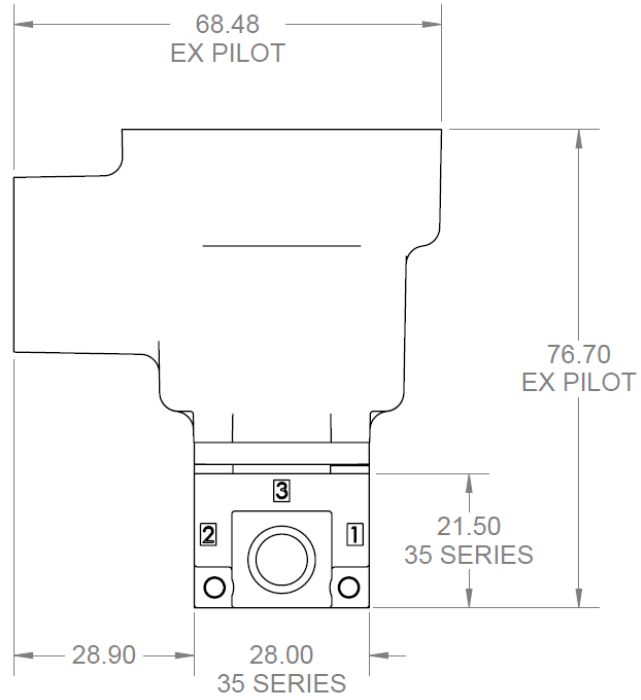

45A-FA1-DXXB-0EX shown with optional spacer

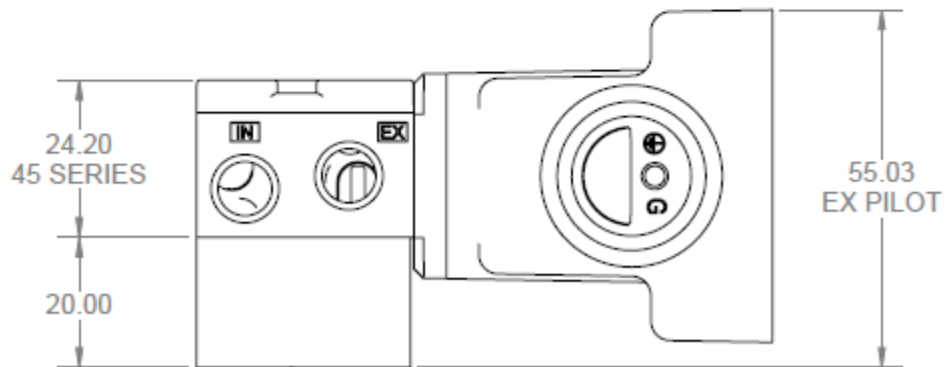
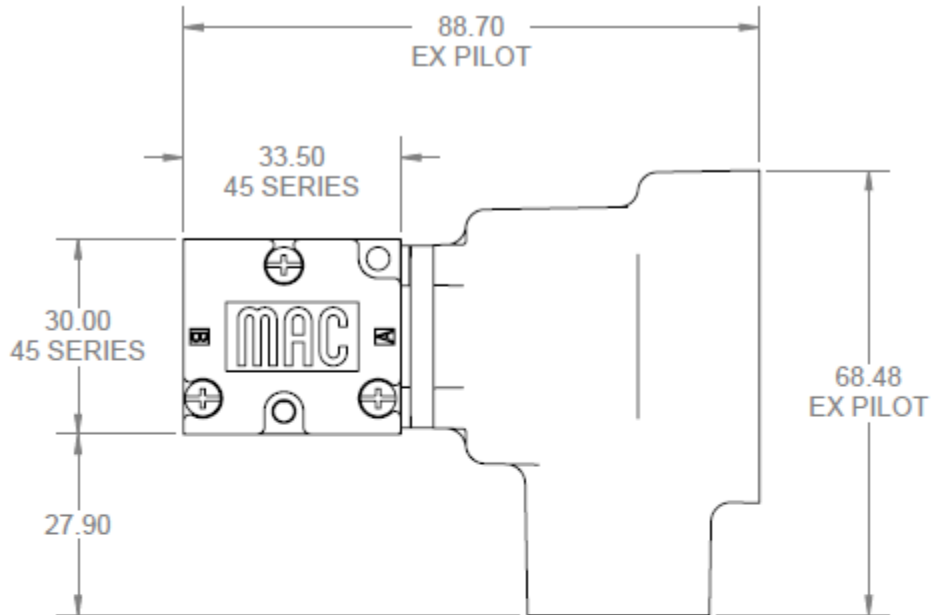

#N-45047: 45 SERIES SPACER PLATE KIT
(Optional)

52A-11-A0A-DM-DXXB-0EX
411A-A0A-DM-DXXB-0EX

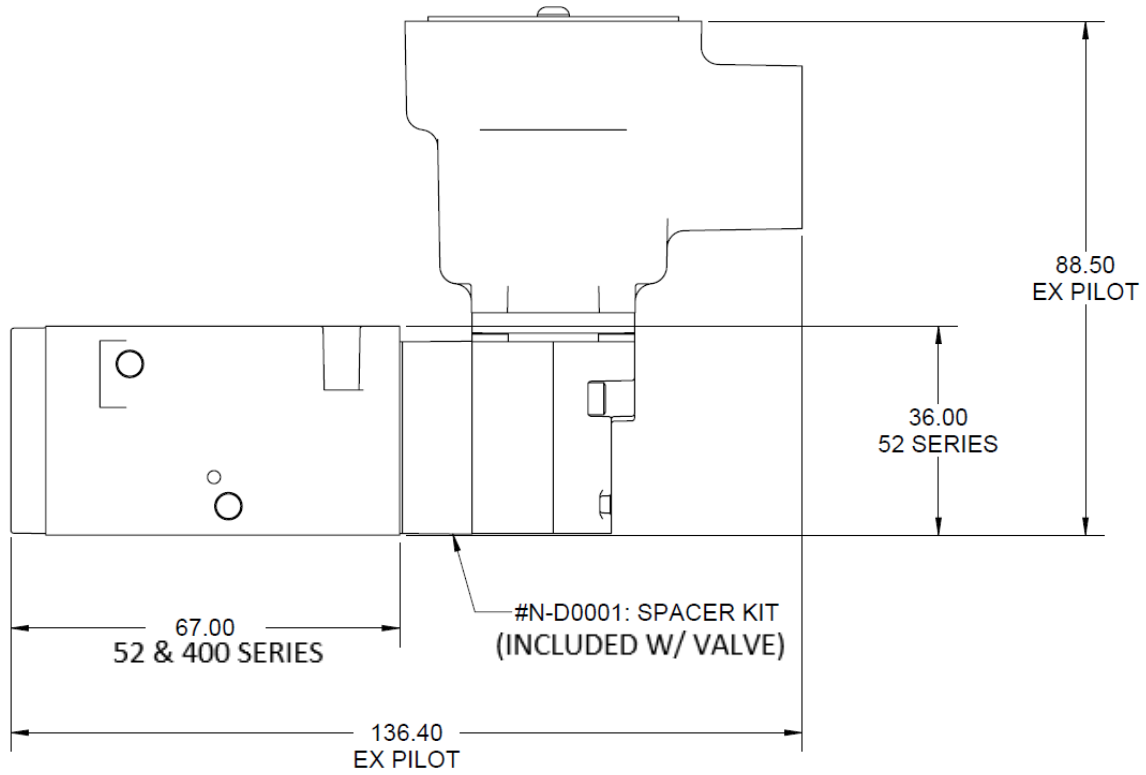

53A-1A0-DM-DXXB-0EX

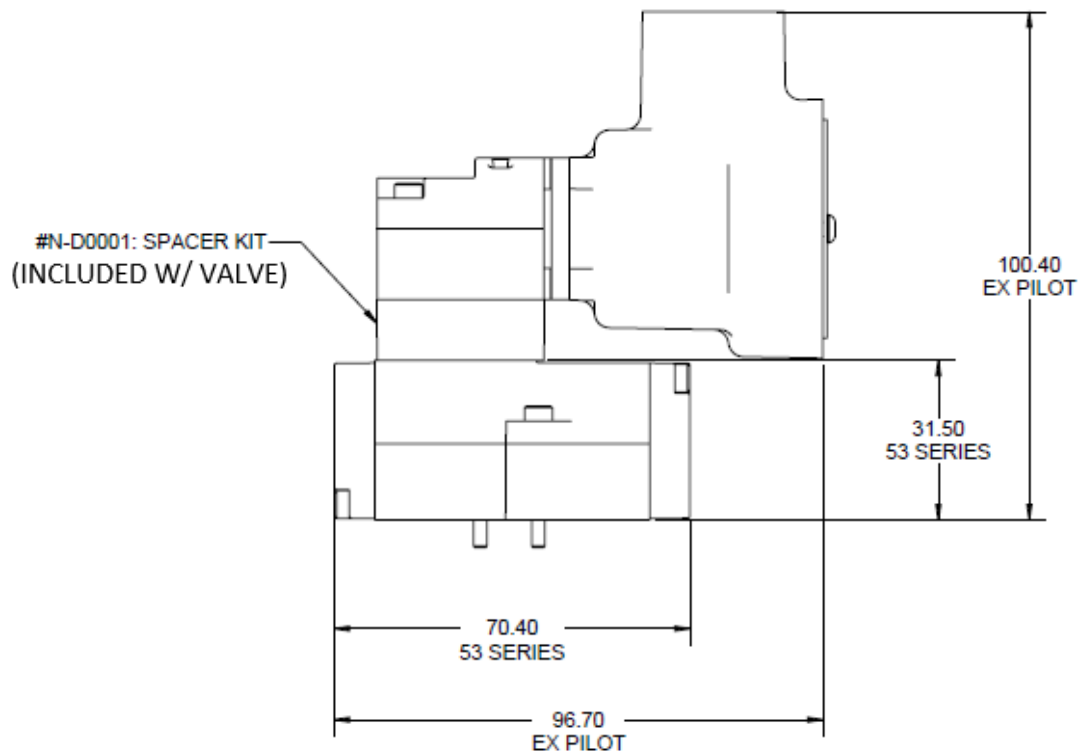
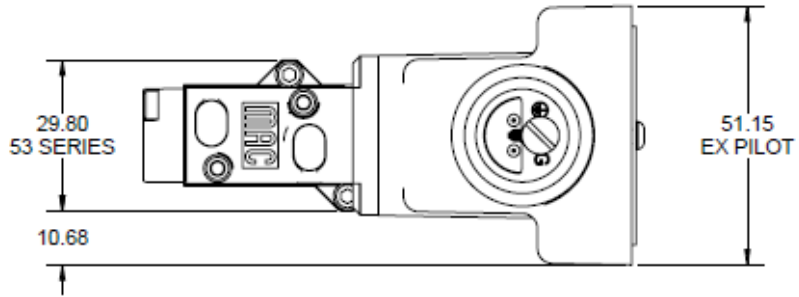

54A-AA-000-DM-DXXB-0EX

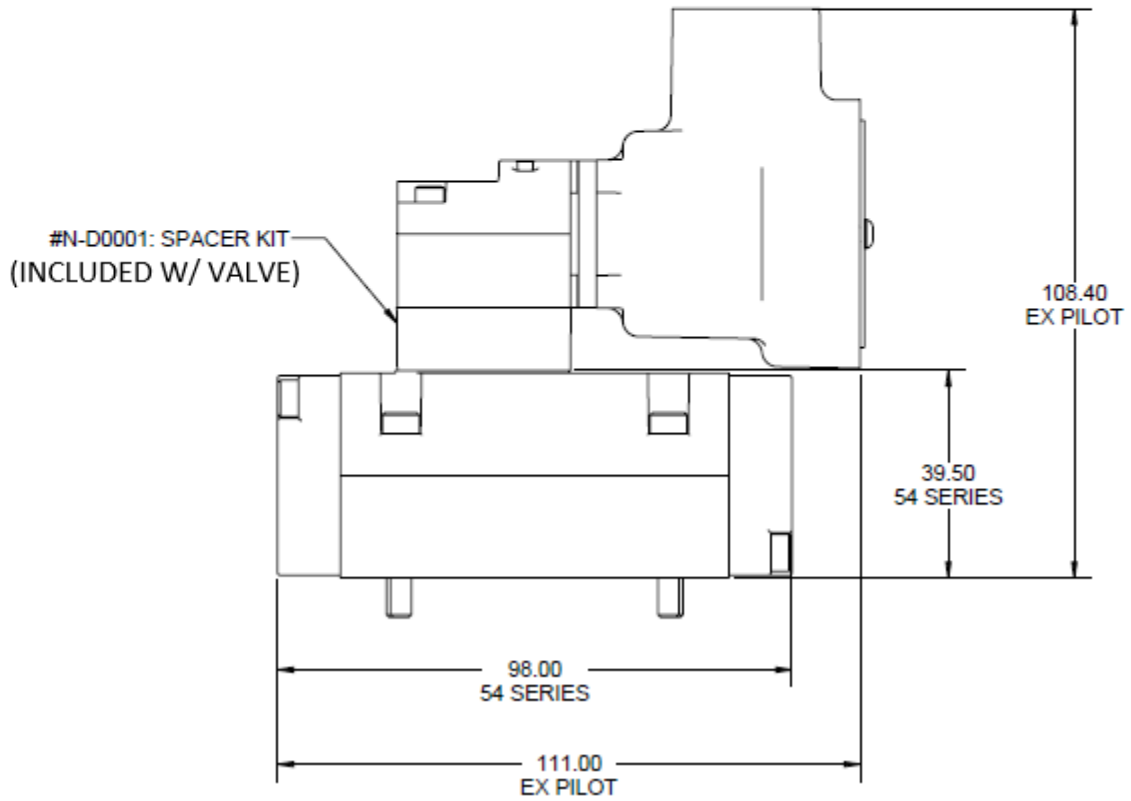
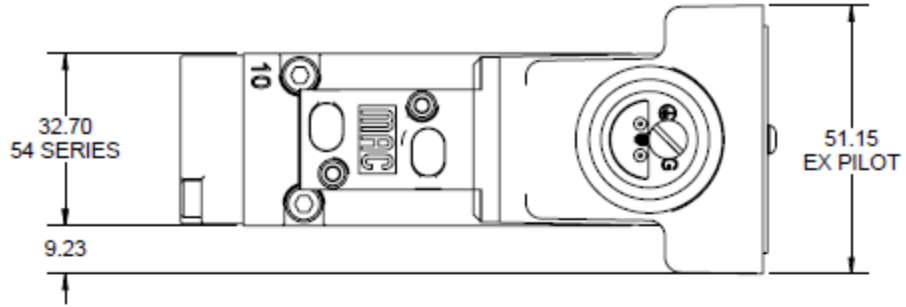

92B-BAB-000-DM-DXXB-0EX

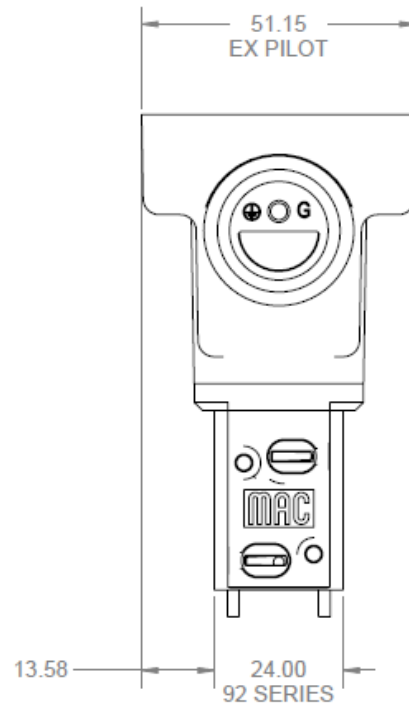
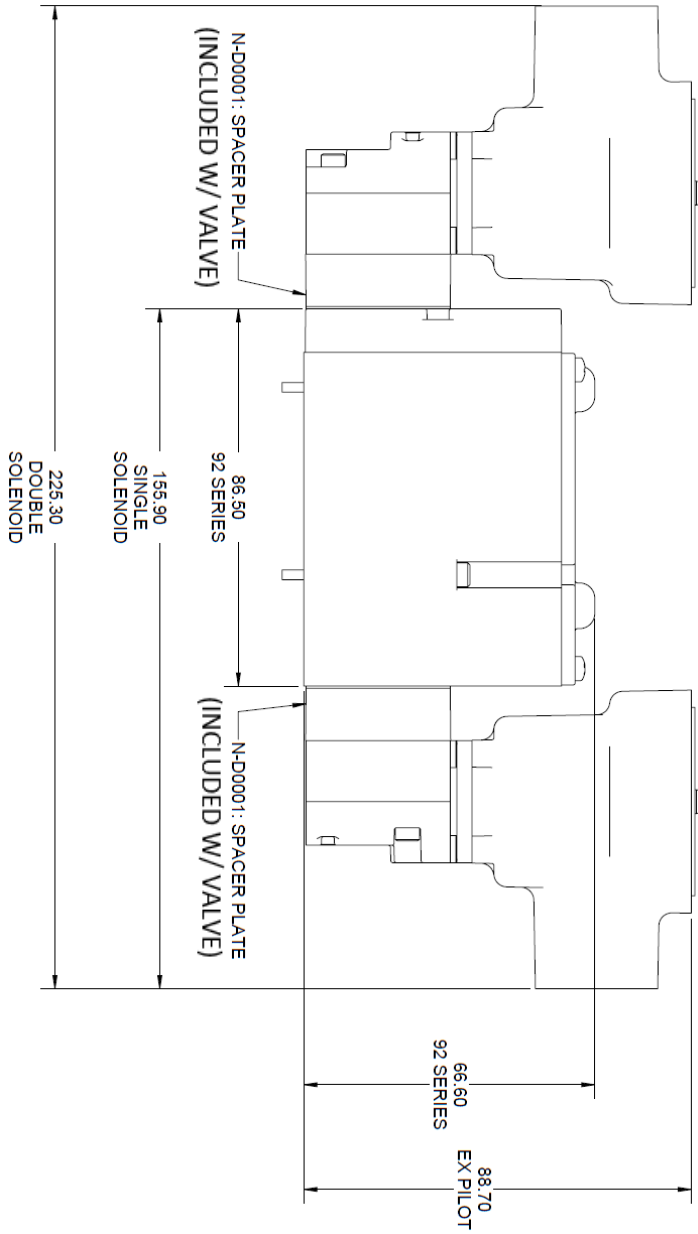

93A-BAA-000-DM-DXXB-0EX

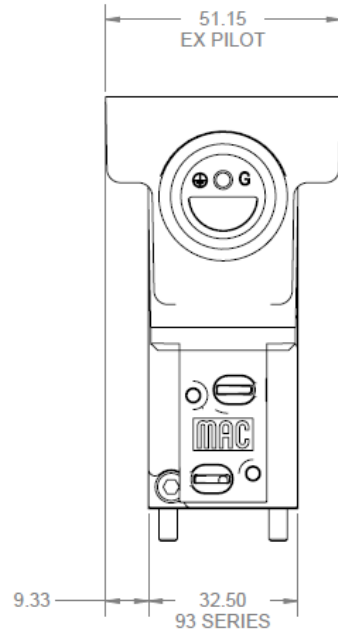
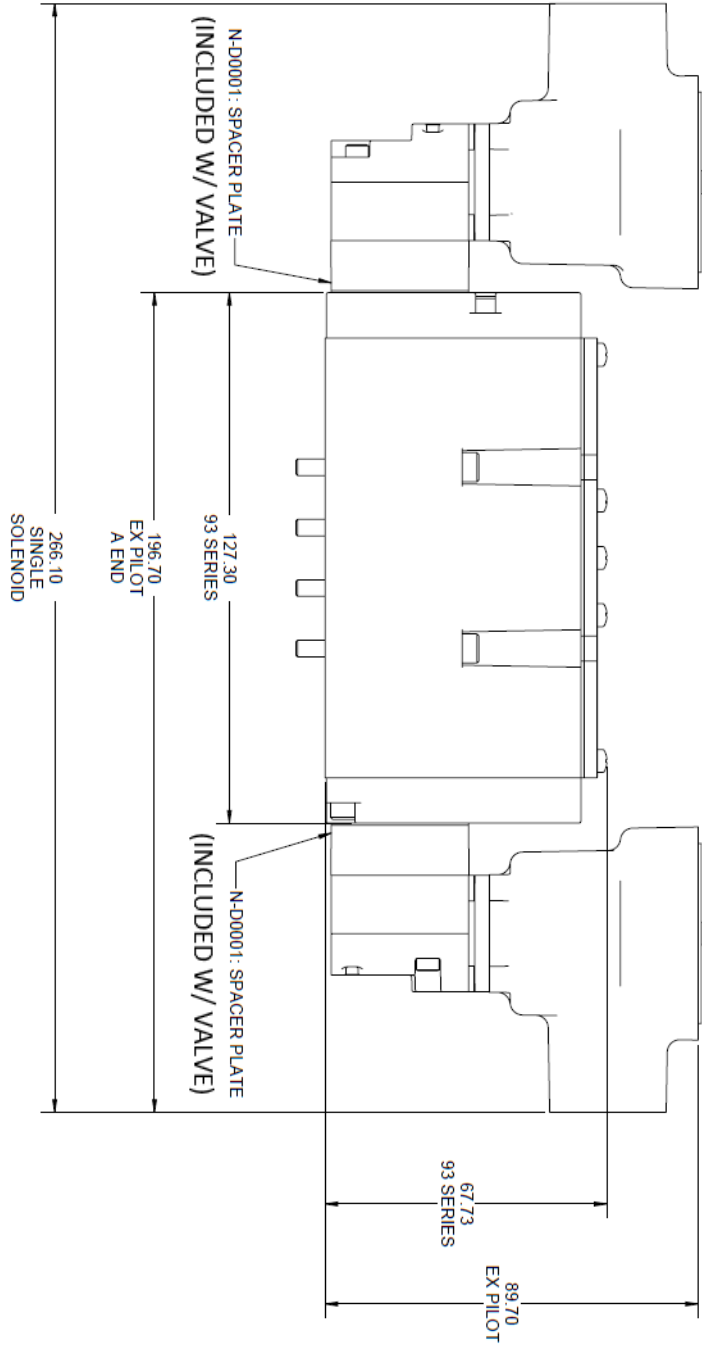

411A-B0A-DM-DXXB-0EX MOD 1080
Shown with optional Namur spacer kit

